

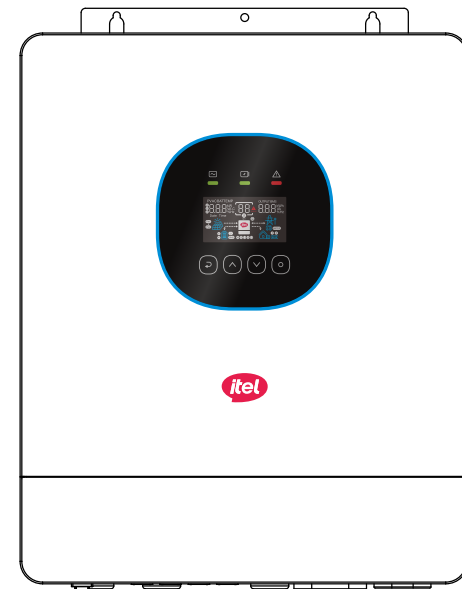

User Guide

Hybrid Inverter

IPV-3K24UPRO



Contents

ABOUT THIS MANUAL	01
Purpose	01
Scope	01
Safety instructions	01
WARNING MARKS	02
INTRODUCTION	03
Features	03
Basic system architecture	03
PRODUCT OVERVIEW	04
SPECIFICATIONS	05
INSTALLATION	08
Safety guidance	08
Unpacking and inspection	08
Preparation	09
Mounting the unit	09
Battery connection	10
AC input/output connection	11
PV connection	12
Wiring System for Inverter	14
OPERATION	15
Power on/off	15
Operation and display panel	15
LCD display icons	16
LCD operation flow chart	18
Base information page	18
Setting page	20
Energy stored data page	26
BMS information page	26
Rated information page	27
Lithium battery communication	28
PARALLEL INSTALLATION GUIDE	29
Introduction	29
Mounting the unit	29
Package contents	30
Wiring connection	30
LCD setting and display	33
Commissioning	33
WARNING CODE TABLE	35
FAULT CODE TABLE	35

ABOUT THIS MANUAL

Purpose

This manual describes the assembly, installation, operation, warning code and fault code of this unit. Please read this manual carefully before installations and operations. Keep this manual for future reference.

Scope

This manual provides safety and installation guidelines as well as information on tools and wiring.









Safety Instructions

 **WARNING: This chapter contains important safety and operating instructions. Read and keep this manual for future reference.**

1. Before using the unit, read all instructions and cautionary markings on the unit, the batteries and all appropriate sections of this manual.
2. **CAUTION** To reduce risk of injury, charge only deep-cycle lead acid type rechargeable batteries. Other types of batteries may burst, causing personal injury and damage.
3. Do not disassemble the unit. Take it to a qualified service center when service or repair is required. Incorrect re-assembly may result in a risk of electric shock or fire.
4. To reduce risk of electric shock, disconnect all wirings before attempting any maintenance or cleaning. Turning off the unit will not reduce this risk.
5. **CAUTION** Only qualified personnel can install this device with battery.
6. **NEVER** charge a frozen battery.
7. For optimum operation of this inverter/charger, please follow required spec to select appropriate cable size. It's very important to correctly operate this inverter/charger.
8. Be very cautious when working with metal tools on or around batteries. A potential risk exists to drop a tool to spark or short circuit batteries or other electrical parts and could cause an explosion.
9. Please strictly follow installation procedure when you want to disconnect AC or DC terminals. Please refer to INSTALLATION section of this manual for the details.
10. Fuse is provided as over-current protection for the battery supply.
11. **GROUNDING INSTRUCTIONS** This inverter/charger should be connected to a permanent grounded wiring system. Be sure to comply with local requirements and regulation to install this inverter.
12. **NEVER** cause AC output and DC input short circuited. Do NOT connect to the mains when DC input short circuits.
13. **WARNING!!** Only qualified service persons are able to service this device. If errors still persist after following troubleshooting table, please send this inverter/charger back to local dealer or service center for maintenance.

WARNING MARKS

Warning marks inform users of conditions which can cause serious physical injury or death, or damage to the device. They also tell users how to prevent the dangers. The warning marks used in this operation manual are shown below:

Mark	Name	Instruction	Abbreviation	
	Danger	Danger	Serious physical injury or even death may occur if not follow relevant requirements.	
	Warning	Warning	Physical injury or damage to the device may occur if not follow relevant requirements.	
	Forbid	Electrostatic sensitive	Damage may occur if relevant requirements are not followed.	
	Hot	High temperature	Do not touch the base of the inverter as it will become hot.	
	Note	Note	The procedures taken for ensuring proper operation.	Note

INTRODUCTION

This is a multi-function inverter/charger, combining functions of inverter, MPPT solar charger and battery charger to offer uninterruptible power support with portable size. Its comprehensive LCD display offers user-configurable and easy-accessible button operation such as battery charging current, AC/solar charger priority, and acceptable input voltage based on different applications.

Features

- Pure sine wave inverter
- Built-in MPPT solar charge controller
- Configurable input voltage range for home appliances and personal computers via LCD setting
- Configurable battery charging current based on applications via LCD setting
- Configurable AC/Solar Charger priority via LCD setting
- Compatible to mains voltage or generator power
- Auto restart while AC is recovering
- Overload / Over temperature / short circuit protection
- Inverter running without battery
- Lithium battery activation function
- Cold start function
- Intelligent fan control greatly reduces fan noise

Basic System Architecture

The following illustration shows basic application for this inverter/charger. It also includes following devices to have a complete running system:

- Generator or Utility
- PV modules (option)

Consult with your system integrator for other possible system architectures depending on your requirements.

This inverter can power all kinds of appliances in home or office environment, including motor-type appliances such as tube light, fan, refrigerator and air conditioner.

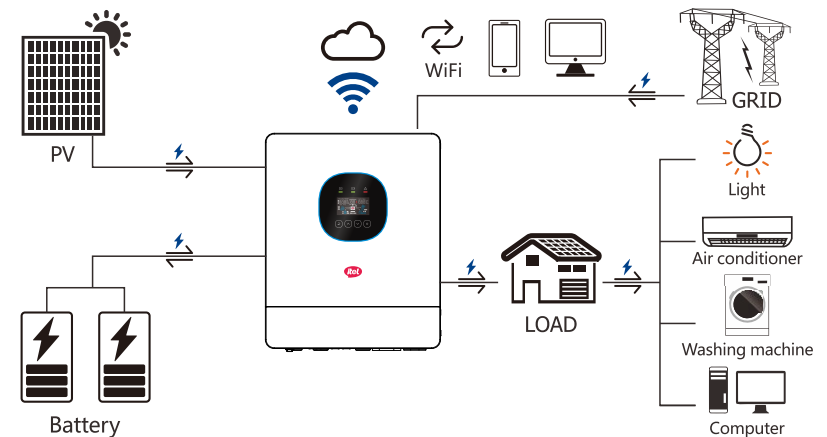

PRODUCT OVERVIEW

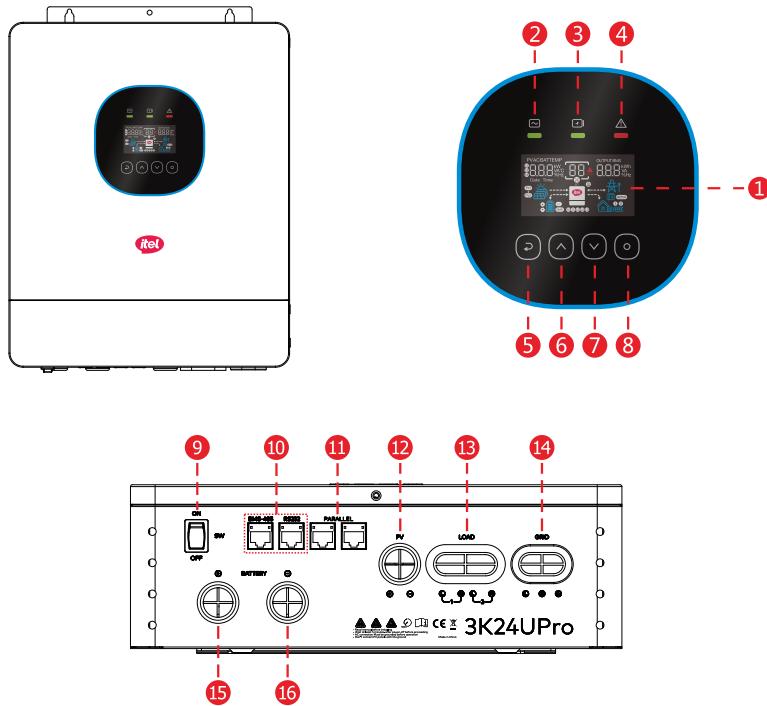

- | | |
|--------------------------------------|-----------------------------------|
| 1. LCD display | 9. Switch |
| 2. Utility bypass/Inverter indicator | 10. Communication connection port |
| 3. Charging indicator | 11. Parallel connection-CAN port |
| 4. Fault or warning indicator | 12. PV input connection port |
| 5. ESC button | 13. AC output/Generator port |
| 6. UP button | 14. AC input port |
| 7. Down button | 15. Battery+ connection port |
| 8. Enter button | 16. Battery- connection port |

10 Definition of BMS communication port pin

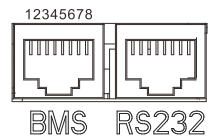

NO.	BMS(3.6KVA)	RS-232
1	NC	RS232-TXD
2	NC	RS232-RXD
3	NC	VDD
4	NC	VSS
5	NC	NC
6	VSS	NC
7	RS485-A	NC
8	RS485-B	VSS

SPECIFICATIONS

Line Mode Specifications	
Model	IPV-3K24UPRO
Rated Output Power	3600VA
	3000W
Nominal DC Input Voltage	24V
Input Voltage Waveform	Sinusoidal (utility or generator)
Nominal Input Voltage	230Vac
Low Line Voltage Disconnect	90Vac±3V(For Home Appliances: APL)170Vac±3V(For Computers: UPS)
Low Loss Voltage Re-connect	100Vac±3V(For Home Appliances: APL)180Vac±3V(For Computers: UPS)
High Line Voltage Disconnect	280Vac±3V
High Line Voltage Re-connect	270Vac±3V
Max AC Input Voltage	280Vac±3V
Nominal Input Frequency	50Hz/60Hz(Auto detection)
Low Line Frequency Disconnect	40±1Hz
Low Line Frequency Re-connect	42±1Hz
High Line Frequency Disconnect	65±1Hz
High Line Frequency Re-connect	63±1Hz
Output Voltage Waveform	As same as input waveform
Output Short Circuit Protection	Line mode: Circuit Breaker; Battery mode: Electronic Circuits
Efficiency (Line Mode)	>95%(Rated R load, battery 50% charged)
Transfer Time (Single unit)	10ms typical (UPS); 20ms typical (Appliances)
Transfer Time (Parallel)	50ms typical
Pass Through Without Battery	Yes
Max. Bypass Overload Current	20A
Max. Bypass Input Current	20A
Max. Inverter/Rectifier Current	13.63A/3000W









Utility Charge Mode Specifications			
Model	IPV-3K24UPRO		
Nominal Input Voltage	230Vac		
Input Voltage Range	90-280Vac		
Nominal Output Voltage	Dependent on battery type		
Max. Grid Charge Current	125A		
Charge Current Regulation	10A-Max. Grid Charge Current (Adjustable unit is 1A)		
Over Charge Protection	Yes		
Grid charging Current (I.max/I.md/I.min)	125A/60A/30A		
Relationship between battery charging current and grid voltage.			
Solar Charging & Grid Charging			
Max. PV Open Circuit Voltage	500V		
PV voltage range	70V-425V		
Max. Input Power	4500W		
Max. Solar Charging Current	125A		
Max. Charging Current(PV+Grid)	125A		
Max.PV Input Current	18A		
Min. Startup Voltage	75V		
Charge Algorithm			
Algorithm	Three stage: Boost CC (Constant current stage)-> Boost CV(Constant voltage stage)-> Float FV(Constant voltage stage)		
Charging Curve			
Battery Type Setting	Battery Type	Boost CC/CV	Float
	AGM	28.2V	27V
	Flooded	29.2V	27V
	Self-defined	Adjustable, up to 30V	
	Lithium	Adjustable, up to 30V	

Inverter Mode Specifications	
Model	IPV-3K24UPRO
Rated Output Power	3600VA
	3000W
Nominal DC Input Voltage	24V
DC Max.charging/Discharging current	125A/135A
Output Voltage Waveform	Pure sine wave
Nominal Output Voltage	230Vac
Nominal Output Frequency(Hz)	50±0.3Hz/60±0.3Hz(Adjustable)
Parallel capability	NC
Peak Efficiency	92%
Over-Load Protection(SMPS load)	2s@≥150%load; 10s@105%~150%load
Surge Rating	2* rated power for 2s
Capable of Starting Electric	Yes
Output Short Circuit Protection	Yes
Cold Start Voltage	23V
Low DC Input Shut-down Load < 50%/@Load ≥ 50%	21.5V/21V
High DC Input Alarm & Fault	31V±0.2V
High DC Input Recovery	29V±0.2V
Battery Voltage Limitation (V.bat0/V.bat1/V.bat2)	21V/24V/31V
When battery voltage is lower than "V.bat1", output power will be derated. The minimum AC output voltage is 190V.	
Temperature Limitation(Td)	45°C/55°C
When ambient temperature is higher than 45°C/55°C, output power will be derated. The minimum AC output voltage is 210V.	
General Specifications	
Operating Temperature	-10°C ~ 55°C
Range Storage Temperature	-15°C ~ 60°C
Net Weight(kg)	9.2kg
Gross Weight(kg)	11.4kg
Product Size(D*W*H)	347x445x120mm
Package Dimension(D*W*H)	560x465x240mm

INSTALLATION

Safety Guidance

Warning marks inform users of conditions which can cause serious physical injury or death, or damage to the device. They also tell users how to prevent the dangers. The warning marks used in this operation manual are shown below:

	<ul style="list-style-type: none"> After receiving this product, first confirm the product package is intact. If any question, contact the logistic company or local distributor immediately. The installation and operation of inverter must be carried out by professional technicians who have received professional trainings and thoroughly familiar with all the contents in this manual and the safety requirements of the electrical system.
	<ul style="list-style-type: none"> Do not carry out connection/disconnection, unpacking inspection and unit replacement operations on the inverter when power source is applied. Before wiring and inspection, users must confirm the breakers on DC and AC side of inverter are disconnected and wait for at least 5 minutes.
	<ul style="list-style-type: none"> Ensure there is no strong electromagnetic interference caused by other electronic or electrical devices around the installation site. Do not refit the inverter unless authorized. All the electrical installation must conform to local and national electrical standards.
	<ul style="list-style-type: none"> Do not touch the housing of the inverter or the radiator to avoid scald as they may become hot during operation.
	<ul style="list-style-type: none"> Ground with proper technics before operation.
	<ul style="list-style-type: none"> Do not open the surface cover of the inverter unless authorized. The electronic components inside the inverter are electrostatic sensitive. Do take proper anti-electrostatic measures during authorized operation.
	<ul style="list-style-type: none"> The inverter needs to be reliably grounded.
	<ul style="list-style-type: none"> Ensure that DC and AC side circuit breakers have been disconnected and wait at least 5 minutes before wiring and checking.

Unpacking and Inspection

Before installation, please inspect the unit. Be sure that nothing inside the package is damaged. You should have received the following items inside of package:

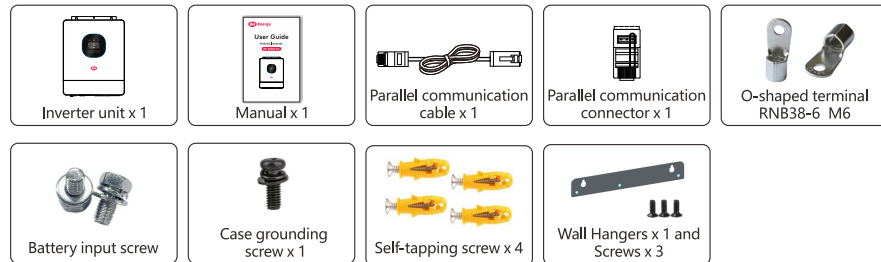

Preparation

Before connecting all wirings, please take off bottom cover by removing three or four screws as shown below.

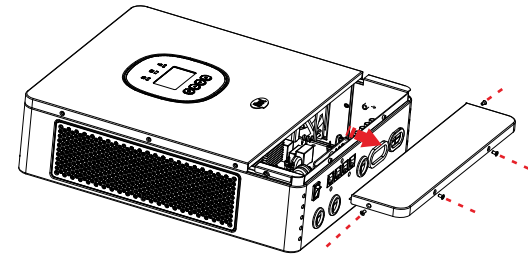

Mounting the Unit

Consider the following points before selecting where to install:

- Do not mount the inverter on flammable construction materials.
- Mount on a solid surface.
- Install this inverter at eye level in order to allow the LCD display to be read at all times.
- The ambient temperature should be between -10°C and 55°C to ensure optimal operation.
- The recommended installation position is to be adhered to the wall vertically.
- Be sure to keep other objects and surfaces as shown in the right diagram to guarantee sufficient heat dissipation and to have enough space for removing wires.

Installation Steps:

- Install the bracket with M4 screw to connect the bracket with the inverter;
- Then install the inverter on the wall with M4 self-tapping screw, and leave a distance of 60cm between the inverters, as shown in the figure:

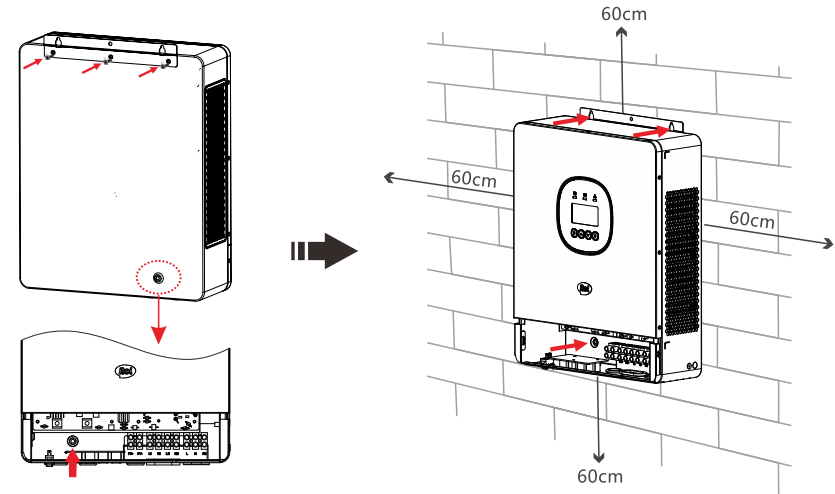

SUITABLE FOR MOUNTING ON CONCRETE OR OTHER NON-COMBUSTIBLE SURFACE ONLY.

Battery Connection

CAUTION: For safety operation and regulation compliance, it's requested to install a separate DC over-current protector or disconnect device between battery and inverter. It may not be requested to have a disconnect device in some applications, however, it's still requested to have over-current protection installed. Please refer to typical amperage in below table as required fuse or breaker size.

WARNING! All wiring must be performed by a qualified personnel.

WARNING! It's very important for system safety and efficient operation to use appropriate cable for battery connection. To reduce risk of injury, please use the proper recommended cable and terminal size as below.

Model	Gauge	Cable(mm ²)	Torque Value
3.6KVA	1*1AWG	50	2 Nm

Please follow below steps to implement battery connection:

1. Assemble battery ring terminal based on recommended battery cable and terminal size.
2. Connect all battery packs as units requires. It's suggested to connect at least 200Ah capacity battery.
3. Insert the ring terminal of battery cable flatly into battery connector of inverter and make sure the bolts are tightened with torque of 2 Nm. Make sure polarity at both the battery and the inverter/charge is correctly connected and ring terminals are tightly screwed to the battery terminals.

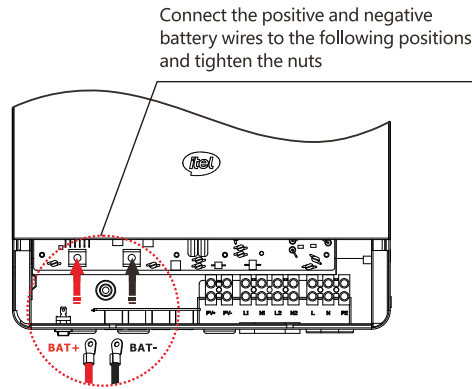

WARNING: Shock hazard
Installation must be performed with care due to high battery voltage in series.

CAUTION!! Do not place anything between the flat part of the inverter terminal and the ring terminal. Otherwise, overheating may occur.
CAUTION!! Do not apply anti-oxidant substance on the terminals before terminals are connected tightly.
CAUTION!! Before making the final DC connection or closing DC breaker/disconnector, be sure positive (+) must be connected to positive (+) and negative (-) must be connected to negative (-).

AC Input/Output Connection

CAUTION!! Before connecting to AC input power source, please install a separate AC breaker, a self resetting overvoltage and undervoltage protector and a SPD (Surge Protection Device) between inverter and AC input power source. This will ensure the inverter can be securely disconnected during maintenance and fully protected from over current of AC input. The recommended spec of AC breaker is 28A for 4kVA and 50A for 6kVA.

CAUTION!! There are two terminal blocks with "IN" and "OUT" markings. Please do NOT mis-connect input and output connectors.
WARNING! All wiring must be performed by qualified personnel.
WARNING! It's very important for system safety and efficient operation to use appropriate cable for AC input connection. To reduce risk of injury, please use the proper recommended cable size as below.

Suggested cable requirement for AC wires:

Model	Gauge	Cable (mm ²)	Torque value
3.6KVA	10AWG	6	1.2Nm

Recommended circuit breaker type for AC input:

Models	Maximum bypass	Recommended circuit breaker
3.6KVA	20A	2P-32A

Please follow below steps to implement AC input/output connection:

1. Before making AC input/output connection, be sure to open DC protector or disconnector firstly.
2. Remove insulation sleeve 10mm for six conductors. And shorten phase Land neutral conductor N3mm.

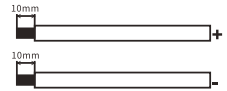

⊕ → Ground (yellow-green)
L → LINE (brown or black)
N → Neutral (blue)

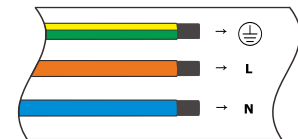

3. Insert AC input wires according to polarities indicated on terminal block and tighten the terminal screws. Be sure to connect PE protective conductor (⊕) first.

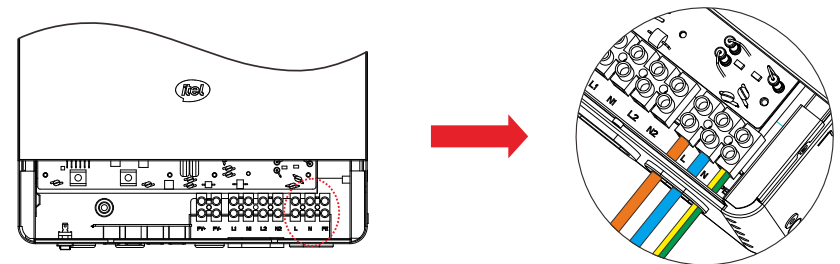



WARNING:

Be sure that AC power source is disconnected before attempting to hardwire it to the unit.

4. Then, insert AC output/Generator input wires according to polarities indicated on terminal block and tighten terminal screws. Be sure to connect PE protective conductor (⊕) first.

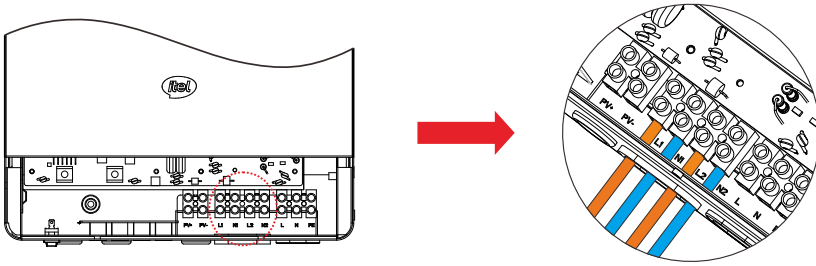

5. Make sure the wires are securely connected.

CAUTION: Important

Be sure to connect AC wires with correct polarity. If L and N wires are connected reversely, it may cause utility short-circuited when these inverters are worked in parallel operation.

CAUTION: Appliances such as air conditioner are required at least 2~3 minutes to restart because it's required to have enough time to balance refrigerant gas inside of circuits. If a power shortage occurs and recovers in a short time, it will cause damage to your connected appliances. To prevent this kind of damage, please check manufacturer of air conditioner if it's equipped with time-delay function before installation. Otherwise, this inverter/charger will trig overload fault and cut off output to protect your appliance but sometimes it still causes internal damage to the air conditioner.

PV Connection



CAUTION: Before connecting to PV modules, please install separately a DC circuit breaker between inverter and PV modules.

WARNING! All wiring must be performed by qualified personnel.

WARNING! It's very important for system safety and efficient operation to use appropriate cable for PV module connection. To reduce risk of injury, please use the proper recommended cable size as below.

Model	Cable Size	Cable (mm ²)	Torque
3.6KVA	10AWG	6	1.2Nm

PV Module Selection:

When selecting proper PV modules, please be sure to consider below parameters:

1. Open circuit Voltage (Voc) of PV modules not exceeds max. PV array open circuit voltage of inverter.
2. Max. power voltage (Vmp) should be during PV array MPPT voltage range.

Solar Charging Mode

INVERTER MODEL	3.6KVA
Max. PV Array Open Circuit Voltage	500V
PV Array MPPT Voltage Range	70-425V

Please follow below steps to implement PV module connection:

1. Remove insulation sleeve 10mm for positive and negative conductors.



2. Check correct polarity of connection cable from PV modules and PV input connectors. Then, connect positive pole (+) of connection cable to positive pole (+) of PV input connector. Connect negative pole (-) of connection cable to negative pole (-) of PV input connector.

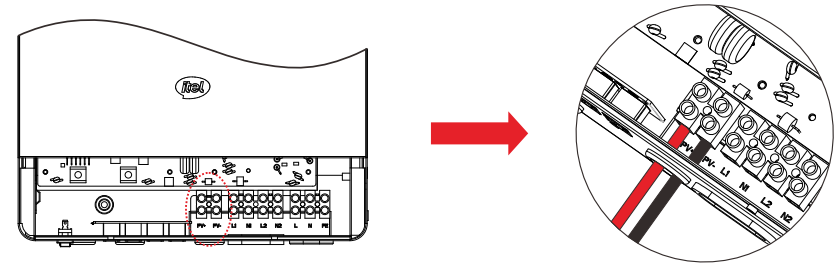

3. Make sure the wires are securely connected.

Wiring System for Inverter

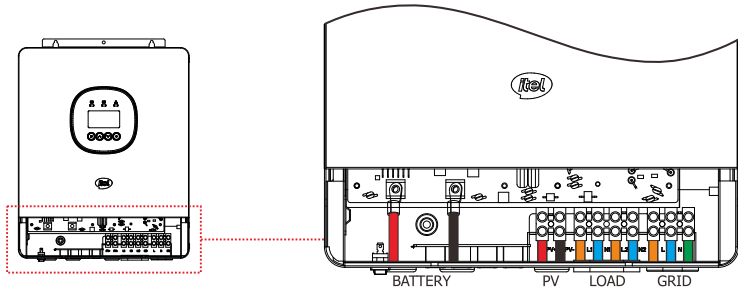

— BAT+/PV+ — BAT-/PV- — L wire — N wire — PE wire

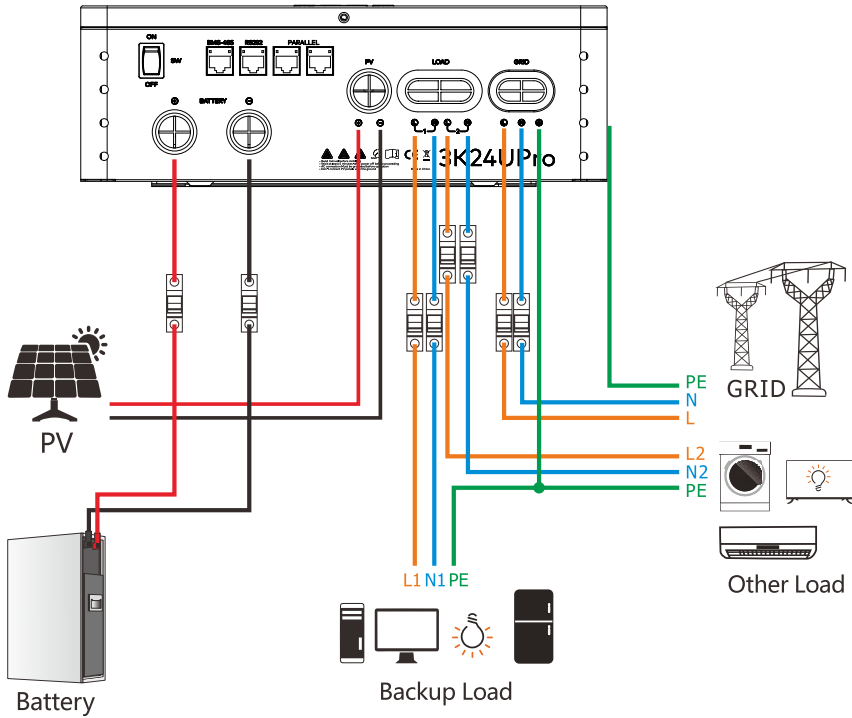

OPERATION

Power ON/OFF

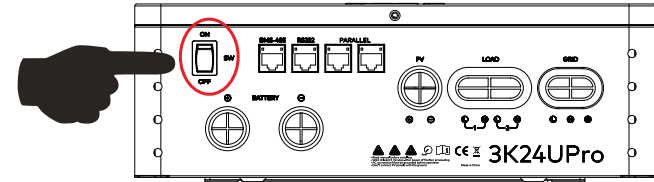

Once the unit has been properly installed and the batteries are connected well, simply press On/Off switch (located on the bottom of the case) to turn on the unit.

Operation and Display Panel

The operation and display panel, shown in below chart, is on the front panel of the inverter. It includes three indicators, four function keys and a LCD display, indicating the operating status and input/output power information.



Function Key	Icon	Description
ESC		To previous page
UP		To go to previous selection
DOWN		To go to next selection
ENTER		To confirm the selection or go to next page

LED indicator	Icon	Description
Battery		Charging the battery, the LED light flash. If battery is full, the LED light will always-on. The battery is not charged, the LED light will go out.
Utility		Inverter running in utility mode, the LED will always-on.
Inverter		Inverter running in off-grid mode, the LED light will flash. Inverter is not running in off-grid mode, the LED light will go out.
Fault		If inverter in fault event, the LED light will always-on. If inverter in warning event, the LED light will flash. Inverter work normally, the LED light will go out.
Buzzer Information		
Buzzer beep		Press any button, the buzzer will last for 0.1s. Hold on the "ENTER" button. the buzzer will last for 3s. If in fault event, the buzzer will keep going. If in warning event, the buzzer will beep discontinuous (Check more information on the chapter of "Warning Code Table").

LCD display Icons

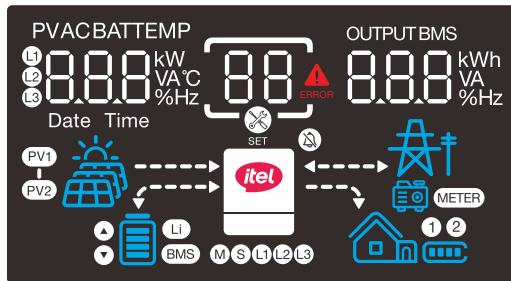

Icon	Function description
Input source information	
	Indicate AC input power, AC input voltage, AC input frequency, PV input voltage, PV input power, battery voltage, apparent power, output frequency, output current, BMS temperature, battery charge and discharge power.
Configuration program and fault information	
	Indicates the setting programs.
	Indicates the warning and fault codes. Warning: flashing with warning code. Fault: lighting with fault code.

Output information	
	Indicate output voltage, output frequency, load percent, load in VA, load in Watt and discharging current.
Battery information	
	Indicates battery level by 0-24%,25-49%,50-74% and 75-100%.
	Indicates lithium battery type.
	BMS Indicates communication is built between inverter and BMS. ▲ Indicates BMS allows battery discharge. ▼ Indicates BMS allows battery charge. Force charge occurs if icon flash.
Mode operation information	
	Indicates load is supplied by utility directly.
	Indicates the utility charger circuit is working.
	Indicates the inverter/charger is working.
	Indicates PV MPPT is working to power load.
	Indicates PV MPPT is working to charge battery.
	Indicates battery is discharging to load.
Mute operation	
	Indicates unit alarm is disabled.

LCD operation flow chart

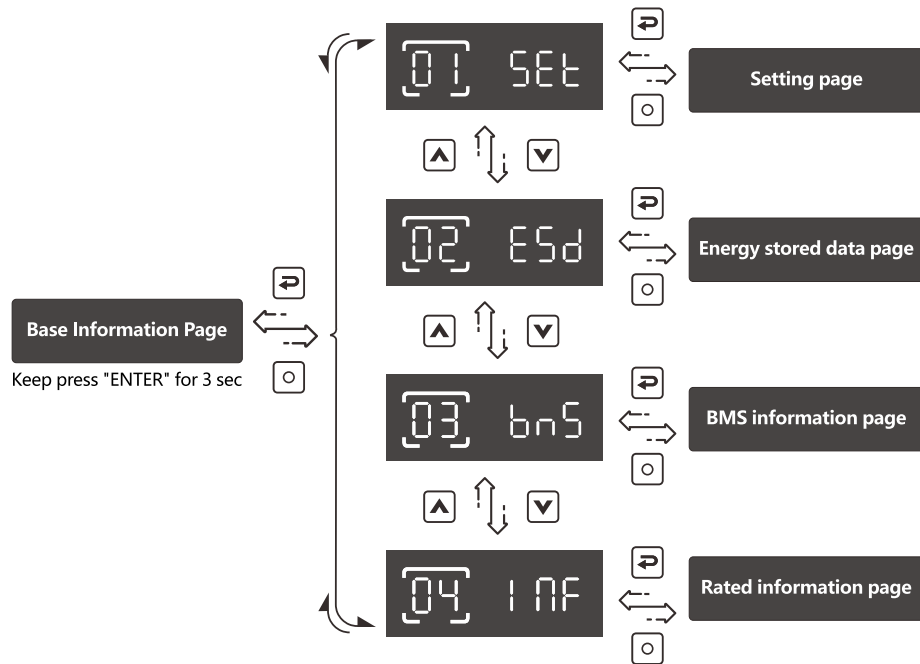

On base information page, pressing and holding "ENTER" key for 3 sec, the unit will enter parameters page. Press "UP" or "DOWN" key to switch the selection and press "ENTER" key to enter selected page. Press "ESC" key to back to previous page.

Base information Page

- The base information will be switched by pressing "UP" or "DOWN" key. The selectable information is switched as below order: (Take the 24V model for example).
- By default, 1 and 2 are displayed, indicating output from both channels. If the second output is disconnected, only 1 is displayed. If item 64 is set to single output, neither 1 nor 2 is displayed.

<p>Default interface Left: PV1 power. Right: Load power and dual output state(1, 2).</p>	<p>Left: PV1 power. Right: PV daily power generation. Middle: PV icon indicates that the current page displays PV information.</p>
---	--

<p>Left: PV1 voltage. Right: PV1 input current. Middle: PV icon indicates that the current page displays PV information.</p>	<p>Left: Grid power, use electricity is "+", feed to grid is "-". Right: Grid daily consume power. Middle: AC icon indicates that the current page displays grid information.</p>
<p>Left: Grid voltage. Right: Grid power, use electricity is "+", feed to grid is "-". Middle: AC icon indicates that the current page displays grid information.</p>	<p>Left: Grid frequency. Right: Grid current. Middle: AC icon indicates that the current page displays grid information.</p>
<p>Left: Battery power(charging is "+", discharging is "-"). Right: Battery SOC(displaying the battery voltage when without BMS). Middle: BA icon indicates that the current page displays battery information.</p>	<p>Left: Battery voltage. Right: Battery charge-discharge current(charge-discharge to display by means of the energy direction). Middle: BA icon indicates that the current page displays battery information.</p>
<p>Left: Output load power in VA. Right: Output load power in Watt. Middle: LD icon indicates that the current page displays output load information.</p>	<p>Left: Output frequency. Right: Output voltage. Middle: LD icon indicates that the current page displays output load information.</p>

Left: Output current.
Right: Percentage of output power.
Middle:  Indicates that the current page displays output load information.

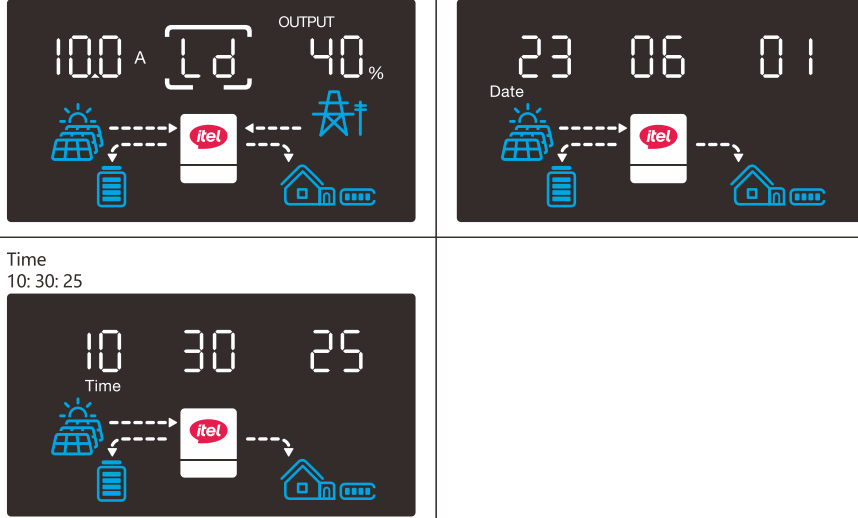



















Time
10:30:25

Setting Page













Press "UP" or "DOWN" button to select setting programs. And then, press "ENTER" button to confirm the selection or ESC button to exit. Keep pressing "UP" or "DOWN" button after 1.5 seconds, it will increase or decrease setting value fastly.













Setting items

		Selectable option		
00	Exit setting		ESC	
01	Battery type setting	Default bAt 	AGM AGM	If "Self-defined" or "Lib" is selected, battery charge voltage and low DC cut-off voltage can be set up in program 03, 04 and 05. If "Lib" is selected, inverter can charge lithium battery when the lithium battery need to be activated. Please make sure lithium battery is connected before you start up inverter. If inverter doesn't connect battery or lithium battery, do not select "Lib" battery type.
		bAt 	Flooded FLD	
		bAt 	self-defined USE	
		bAt 	Lib LIB	
02	BMS type	Default bns 	1	Default Protocol.

		BMS bns 	0	Protocol 0.
03	Bulk charging voltage setting (CV voltage)	Default CV 	24V model 28.2V	If "self-defined" or "Lib" is selected in program 01, this program is enabled. Setting range is from 24.0V to 30.0V.
04	Floating charging voltage	Default FLV 	24V model 27.0V	If "self-defined" or "Lib" is selected in program 01, this program is enabled. Setting range is from 24.0V to 30.0V.
05	Low DC cut-off voltage or SOC	Default bCV 	24V model 21.0V	If "self-defined" or "Lib" is selected in program 01, this program is enabled. Setting range is from 21.0V to 26.0V.
		Default bCV 	10%	
06	Setting battery voltage or SOC point back to utility when selecting "SBU priority" in program 24	Default bUV 	24V model 23.0V	Setting range is from 22.0V to 27.0V. Increment of each click is 0.1V.
		Default bUV 	20%	If the battery type is lithium battery, the set value will change to SOC. Setting range is from 5% to 90%.
07	Setting battery voltage point back to battery mode when selecting "SBU priority" in program 24	Default bbV 	24V model 27.0V	Setting range is from 24.0V to 30.0V. Increment of each click is 0.1V.
		bbV 	Fully charged FUL	Battery should be charged to float charging stage.
		Default bbV 	70%	If the battery type is lithium battery, the set value will change to SOC. Setting range is from 10% to 100%.
09	Max charging current (Utility charge current + PV charging current)	Default bCC 	30A 30A	Setting range is from 1A to 125A. Increment of each click is 1A.
10	Max utility charging current setting	Default CHC 	30A 30A	Setting range is from 1A to 125A. Increment of each click is 1A.
20	AC output mode	Default PAL 	Single S1G	When the units are used in parallel with single phase, please select "PAL" in program 20.

NOTE: The setting value of item "07" should be larger than the setting value of item "06".

		PARL  PARL	Parallel	
21	Output voltage setting	Default OPV  230V	230V	Output voltage configuration.
		OPV  230V	230V	
		OPV  220V	220V	
22	Output frequency setting	Default OPF  50Hz	50Hz	Output frequency configuration.
		OPF  60Hz	60Hz	
23	Utility input range setting	Default AC  APL	Appliance mode	The APL mode is suitable for ordinary household electrical loads. UPS mode is suitable for computer loads. When the effect is not satisfactory, it is recommended to adjust to APL.
		AC  UPS	UPS mode	
24	Output source priority	Default OPS  SUB	PV >> Utility >> Battery	PV provides power to the loads first. If PV is not sufficient, utility will supply power to the loads at the same time. Battery will provide power to loads only when utility is not available.
		OPS  USB	Utility >> PV >> Battery	Utility provides power to the loads first. PV and battery will provide power to loads only when utility is not available.
		OPS  SUBU	PV >> Battery >> Utility	PV provides power to the loads first. If PV is not sufficient, battery will supply power to the loads at the same time. Utility provides power to the loads only when battery voltage drops to the setting point in program 6.
		OPS  INT	Intelligent output source priority	The intelligent priority can use more solar energy and save electricity bills. It is applicable to South Asia (such as Pakistan) and Africa. In this priority mode, the PV provides power to the loads first. If PV is not sufficient, battery or utility will supply power to the loads at the same time. If the energy storage system is not installed with solar panels, do not choose this priority mode.

25	Charger priority	If inverter is working in utility mode, charger priority can be set as below. However, when inverter is working in battery mode, only PV can charge battery.		
		Default CHS  50U	PV and Utility	PV and utility will charge battery together.
		CHS  50	PV First	PV will charge battery first. Utility will charge battery only when PV is unavailable.
27	Overload bypass function	Default LBP  ENA	Enable	If it is enabled, the inverter will switch to utility mode if overload happens in battery mode.
		LBP  DIS	Disable	
28	Overload restart function	Default OLT  ENA	Enable	If it is enabled, the inverter will auto restart when overload occurs.
		OLT  DIS	Disable	
29	Over temperature restart function	Default OLT  ENA	Enable	If it is enabled, the inverter will auto restart when over temperature occurs.
		OLT  DIS	Disable	
40	Backlight of LCD	Default BL  DIS	Disable	If selected, LCD backlight will be off after no button is pressed for 60s.
		BL  ENA	Enable	If selected, LCD backlight will be always-on.
41	Auto return to the first page of display screen	Default BFP  ENA	Enable	If selected, it will automatically return to the first page of display screen (Input voltage / output voltage) after no button is pressed for 60s.
		BFP  DIS	Disable	If selected, the display screen will stay at latest screen user finally switches.

42	Buzzer alarm	Default bEP 42	Enable ENa	If selected, buzzer is allowed to beep.
		bEP 42	Disable diS	If selected, buzzer is not allowed to beep.
43	Energy stored data for PV and load	Default ESd 43	Disable diS	If selected, inverter will erase all historical data of PV and Load energy, and stop record historical data for PV and Load energy.
		ESd 43	Enable ENa	If selected, inverter will record historical data for PV and Load energy. NOTE: Before selected, please double check if date and time is correct, if incorrect, please set date and time in program 50~55.
44	Reset default	Default FSt 44	diS	If selected, default initial settings page.
		FSt 44	ENa	If selected, Enable restores all settings other than the parallel. Output mode setting item (20) to their initial values.
45	Fan work mode	Default FAN 45	PFC	In performance mode, the inverter will perform at it's highest performance.
		FAN 45	bLC	Balanced mode, applicable to the condition of 80% output power and 90A charge current limitation, to reduce additional noise greatly.
		FAN 45	sLC	Silent mode, applicable to the condition of 60% output power and 70A charge current limitation, to reduce additional noise extremely.
46	Failure recovery	Default FtS 46	Disable diS	If selected, when the inverter enter the fault state, the inverter will not exit the fault state or start up again.
		FtS 46	Enable ENa	If selected, when the inverter enter the fault state, the inverter will exit the fault state and start up again.
50	Time setting-Year	Year YER 50	23	Setting range is from 23 to 99.
51	Time setting-Month	Month nON 51	8	Setting range is from 1 to 12.

52	Time setting-Day	Day DAY 52	20	Setting range is from 1 to 31.
53	Time setting-Hour	Hour HOU 53	21	Setting range is from 0 to 23.
54	Time setting-Minute	Minute n 1n 54	43	Setting range is from 0 to 59.
55	Time setting-Second	Second SEC 55	50	Setting range is from 0 to 59.
60	Low DC cut off voltage on second output	Default bCS 60	210V 210V	Setting range is from 21.0V to 26.0V. Increment of each click is 0.1V. This low DC cut-off voltage will be fixed to setting value no matter what percentage of load is connected.
		Default bCS 60	10%	If any type of lithium battery is selected in program 1, this parameter value will be displayed in percentage and value setting is based on battery capacity percentage. Setting range is from 0% to 95%. Increment of each click is 1%.
62	Scheduled time for 2nd AC output on	Default tdO 62	0	Setting range is from 00:00 to 23:00. Increment of each click is 1 hour.
63	Scheduled time for 2nd AC output off	Default tdF 63	0	Within scheduled on/off time setting in program 62 and 63, 2nd AC output will be turn on/off.
64	Dual output Settings	Default SPt 64	Enable AUT	1. The second output is normally on: The grid is power on. 2. The second output is turned off: The grid is power off and the battery voltage or SOC is less than program 60. 3. The second output is recovery: The grid is power off and the battery voltage > program 07 setting voltage, or the SOC > program 07 setting SOC.
		SPt 64	ti n	2nd AC output will be turn on/off according to setting in program 62 and 63.
		SPt 64	Disable diS	Disabled, single output only.

67	Scheduled time for AC charge on	Default ACO		0	Setting range is from 0~23 hour. If the time achieves the setting vaule, AC charge will be allowed/not allowed. If the setting time for AC charge on and off are the same, the AC charge will be allowed always.
68	Scheduled time for AC charge off	Default ACF		0	

Energy stored data Page

The energy stored data will be switched by pressing "UP" or "DOWN" key. The selectable information is switched as below order:

PV generated energy today 88 kWh 	PV generated energy this month 88 kWh 	PV generated energy this year 89 kWh
PV generated energy current in total 348 kWh 	Load consumed energy today 78 kWh 	Load consumed energy this month 78 kWh
Load consumed energy this year 80 kWh 	Load consumed energy in total 272 kWh 	

BMS information Page

The BMS information will be switched by pressing "UP" or "DOWN" key. The selectable information is switched as below order: (Take the 24V model for example)

Battery pack number / mean SOC Connected battery pack number is 4, mean SOC is 97%

BMS voltage /SOC BMS voltage is 24.0V, SOC is 99% on battery pack of address 1 	BMS voltage / current BMS voltage is 24.0V, current is 1A on battery pack of address 1
---	---

BMS highest temperature / lowest temperature BMS highest temperature is 25°C, lowest temperature is 20°C on battery pack of address 1 	BMS fault code / flag BMS fault code is 0, flag is 000 on battery pack of address 1
--	--

Rated information Page

The rated information will be switched by pressing "UP" or "DOWN" key. The selectable information is switched as below order: (Take the 24V model for example)

Rated VA / WATT Rated VA is 3.60kVA, WATT is 3.00kW 	Rated battery voltage / Max. charge current Rated battery voltage is 24.0V, Max.charge current is 125A
Firmware version Firmware version is 1400 	

Lithium Battery Communication

It is allowed to connect lithium battery and build communication only which it has been configured. Please follow below steps to configure communication between lithium battery and inverter.

1. Connect power cable between lithium battery and inverter. Please pay attention to the terminals of positive and negative. Make sure the positive terminal of battery is connected to the positive terminal of inverter, and the negative terminal of battery is connected to the negative terminal of inverter.
2. The communication cable is bundled with lithium battery. Both sides are RJ45 port. One port is connected to the BMS port of inverter and another one is connected to the COMM port of lithium battery.

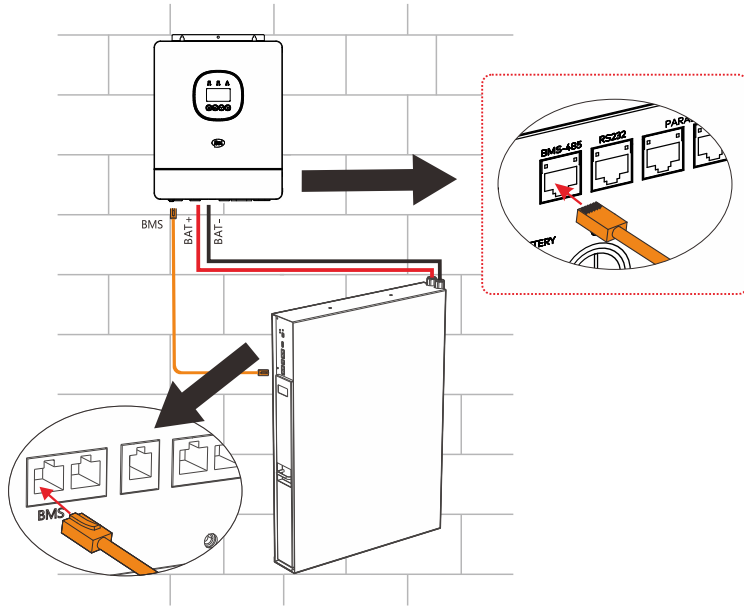

3. Configure battery type to "Lib" in LCD setting No.01.

The battery type is Lib

bAt [01] Lib

And then LCD will show you "Li" icon.

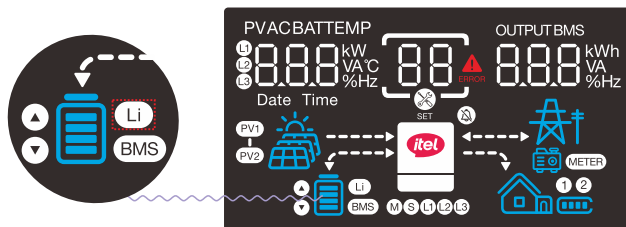

4. Power up lithium battery and inverter. Wait a moment, if the communication is built between them, LCD will show you "BMS" icon as below.

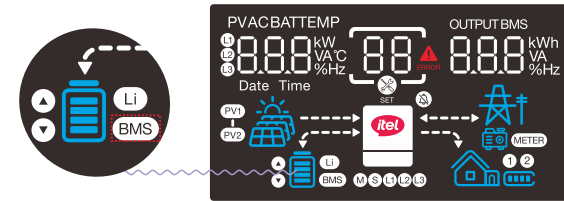

5. Roll LCD real time information pages by pressing "UP" or "DOWN" button, as below page, you can see the parameters of SOC in the communication system.

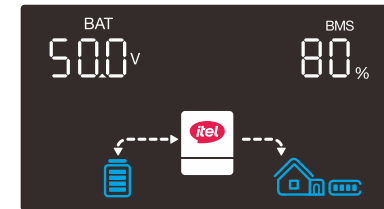

This page means SOC is 80%.

PARALLEL INSTALLATION GUIDE

Introduction

This inverter can be used in parallel with two different operation modes.

1. Parallel operation in single phase with up to 12 units. The supported maximum output power is 36kW/43.2kVA.

NOTE 1: If this unit is bundled with share current cable and parallel cable, this inverter is default supported parallel operation.

NOTE 2: Under parallel operation modes, battery must be connected with inverters.

NOTE 3: Before starting up inverters, please connect all positive (+) and negative (-) wires of battery together.

NOTE 4: This version has not yet enabled the dual-computer operation function.

Mounting the Unit

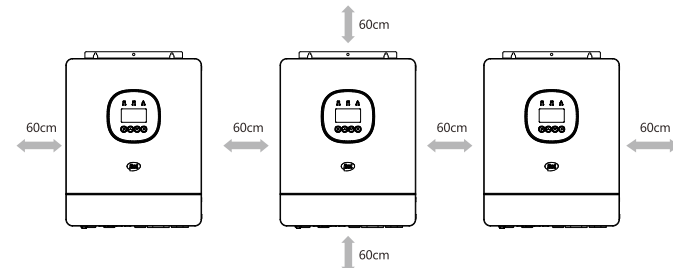

Note: For proper air circulation to dissipate heat, allow a clearance of approx. 60cm to the side and approx. 60cm above and below the unit. Be sure to install each unit in the same level.

Package Contents

In parallel kit, you will find the following items in the package.



Parallel communication cable x 1 pcs



Parallel communication terminal connector x1pcs

Wiring Connection

N Inverters Communication Connection

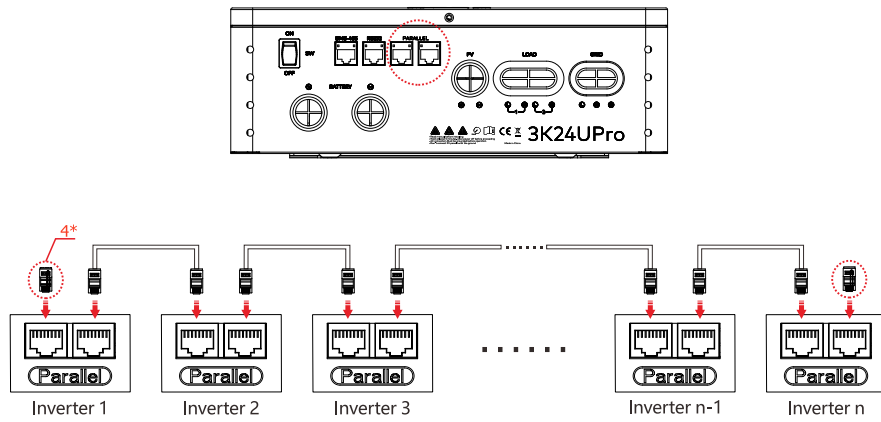

Connect parallel communication cable one by one.

4*: Connect parallel communication connector to the first one and the last one.

Single Phase Parallel connection diagram for two inverters in parallel.

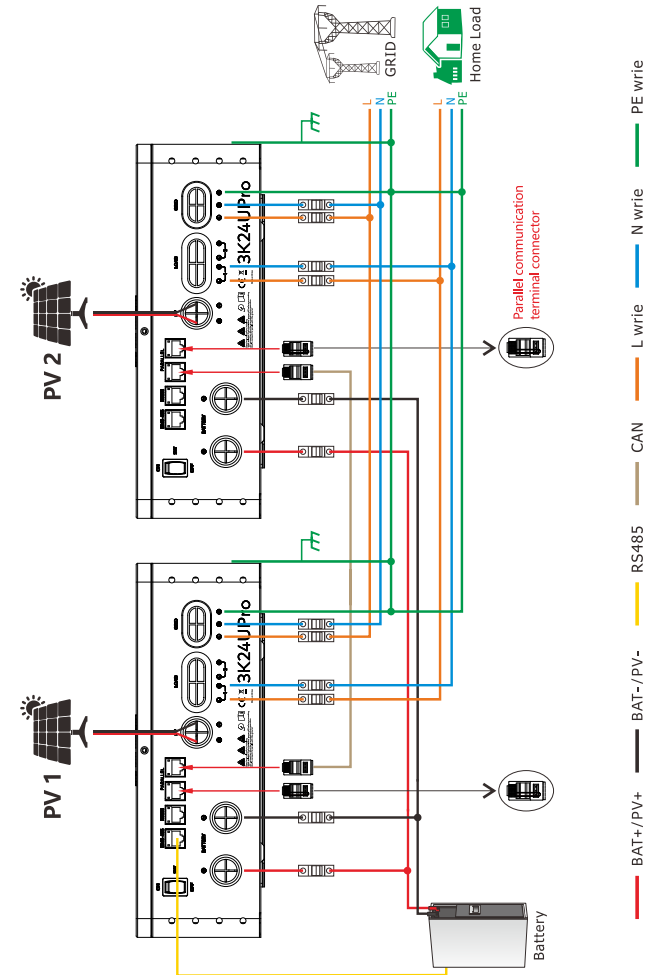

Note: Before starting up inverters, please connect all positive (+) and negative (-) wires of battery together.

Single Phase Parallel connection diagram for three to six inverters in parallel.

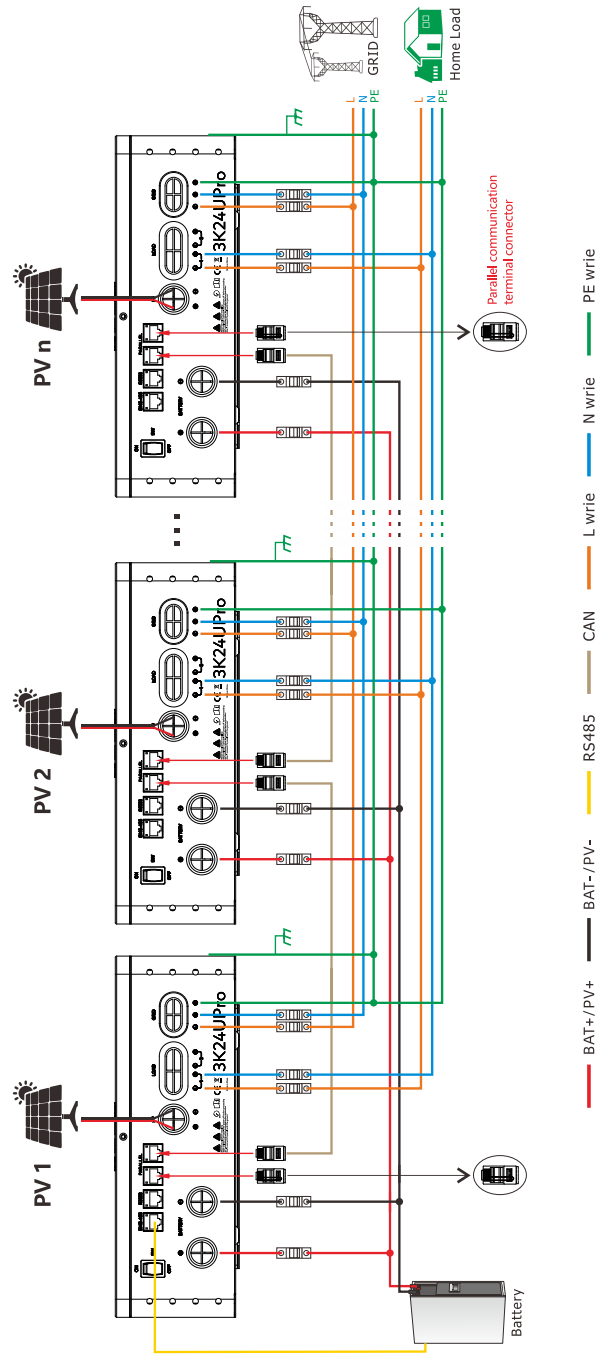

Note:
 1. "n" is the number of parallel connections of the inverters.
 2. Before starting up inverters, please connect all positive (+) and negative (-) wires of battery together.

LCD Setting and Display

Setting Program

20	AC output mode	Single [20] SIG	When the units are used in parallel with single phase, please select "PAL" in program 20. It is required to have at least three inverters or maximum twelve inverters to support three-phase equipment.
		Parallel [20] PAL	

Commissioning

Parallel in single phase

Step 1: Check the following requirements before commissioning:

- Correct wire connection.
- Ensure all breakers in Line wires of load side are open and each Neutral wires of each unit are connected together.

Step 2: Turn on each unit and set "PAL" in LCD setting program 20 of each unit. And then shut down all units.

NOTE: To be safe, it's better to turn off switch when setting LCD program.

Step 3: Turn on each unit.

LCD display in Master unit	LCD display in Slave unit

NOTE: Master and slave units are randomly defined.

Step 4: Switch on all AC breakers of Line wires in AC input. It's better to have all inverters connect to utility at the same time. However, these inverters will automatically restart. If detecting AC connection, they will work normally.

LCD display in Master unit	LCD display in Slave unit

Step 5: If there is no more fault alarm, the parallel system is completely installed.
 Step 6: Please switch on all breakers of Line wires in load side. This system will start to provide power to the load.

Support three-phase equipment

Step 1: Check the following requirements before commissioning:
 • Correct wire connection.
 • Ensure all breakers in Line wires of load side are open and each Neutral wires of each unit are connected together.
 Step 2: Turn on all units and configure LCD program 20 as P1, P2 and P3 sequentially. And then shut down all units.
NOTE: To be safe, it's better to turn off switch when setting LCD program.
 Step 3: Turn on all units sequentially.

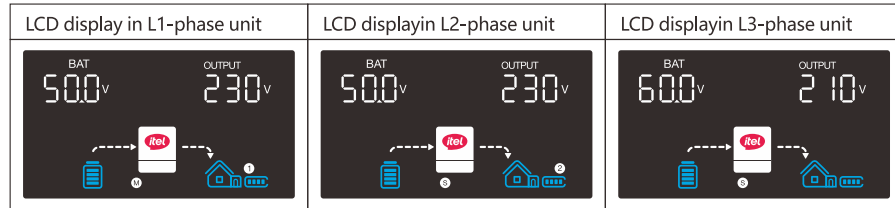

Step 4: Switch on all AC breakers of Line wires in AC input. If AC connection is detected and three phases are matched with unit setting, they will work normally. Otherwise, the AC icon ⚡ will flash and they will not work in line mode.

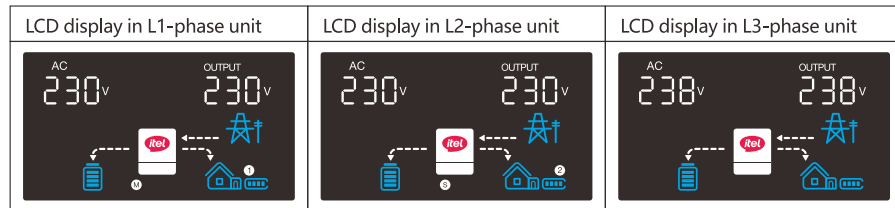

Step 5: If there is no more fault alarm, the system to support 3-phase equipment is completely installed.
 Step 6: Please switch on all breakers of Line wires in load side. This system will start to provide power to the load.
NOTE 1: To avoid overload occurring, before turning on breakers in load side, it's better to have whole system in operation first.
NOTE 2: Transfer time for this operation exists. Power interruption may happen to critical devices, which cannot bear transfer time.

WARNING CODE TABLE

When fault event happens, the fault LED is flashing. At the same time, warning code, icon ⚠ is shown on the LCD screen.

Warning Code	Warning Information	Audible Alarm	Trouble shooting
01	Overload	Beep twice every second	Reduce the loads.
02	Fan is locked (up)	Beep three times every second	Check if the Fans wiring connected well. Replace the fan.
03	Fan is locked (down)	Beep three time every second	Check if the Fans wiring connected well. Replace the fan.
04	Grid over voltage warning	No buzzer alarm	Check whether the grid voltage exceeds the allowable range of the inverter.
05	Output not connected together in parallel mode	No buzzer alarm	Check whether the output load of the inverter is normal, and check whether the inverters are connected together in the same phase.
06	Remote shutdown warning	No buzzer alarm	Check if remote shutdown is enabled via WIFI. Disable the enable or restart the inverter.
07	Second output overload	No buzzer alarm	Reduce the connected load by switching off some equipment, and restart the unit, if the error happens again, please return to repair center.
08	BMS communication failure	No buzzer alarm	Check whether the inverter 01 setting items selected for LI battery. If item 01 is set to lithium battery mode, check whether the communication line between the battery pack and the inverter is properly connected.

FAULT CODE TABLE

When fault event happens, inverter will cut off output, and the fault LED is solid on. At the same time, fault code, icon ERROR is shown on the LCD screen.

Fault Code	Fault information	Trouble Shooting
01	Bus voltage is too high	AC Surge or internal components failed. Restart the unit, if the error happens again, please return to repair center.
02	Bus voltage is too low	Restart the unit, if the error happens again, please return to repair center.
03	Bus soft start fail	Internal components failed. Restart the unit, if the error happens again, please return to repair center.
10	Inverter soft start fail	Internal components failed. Restart the unit, if the error happens again, please return to repair center.
11	Over current or surge detected by Software	Restart the unit, if the error happens again, please return to repair center.
12	Over current or surge detected by hardware	Restart the unit, if the error happens again, please return to repair center.

13	Output voltage is too low	Reduce the connected load. Restart the unit, if the error happens again, please return to repair center.
14	Output voltage is too high	Restart the unit, if the error happens again, please return to repair center.
15	Output short circuited	Check if wiring is connected well and remove abnormal load.
16	Inverter current sensor failed	Restart the unit, if the error happens again, please return to repair center.
17	Current feedback into the inverter is detected.	1. Restart the inverter. 2. Check if L/N cables are not connected reversely in all inverters. 3. For parallel system in single phase, make sure the sharing cables are connected in all inverters. For supporting three-phase system, make sure the sharing cables are connected in the inverters in the same phase, and disconnected in the inverters in different phases. 4. If the problem remains, please contact your installer.
20	Overload time out	Reduce the connected load by switching off some equipment.
21	OP current sensor failed	Restart the unit, if the error happens again, please return to repair center.
22	Sharing current sensor failed	Restart the unit, if the error happens again, please return to repair center.
23	The AC input and output wires are inversely connected	1. Please check AC input and output wires are connected correctly. 2. If this error happens during parallel installation, please check wires connection. If they are connected correctly, please finish parallel installation first, and then restart inverters. 3. If the problem remains, please contact your installer.
24	The output relay exception	Restart the unit, if the error happens again, please return to repair center.
30	Battery voltage is too high	Check if spec and quantity of batteries are meet requirements.
31	Over current happen at DC/DC circuit	Restart the unit, if the error happens again, please return to repair center.
34	DC/DC soft start fail	Restart the unit, if the error happens again, please return to repair center.
36	Over current happen at LLC circuit	Restart the unit, if the error happens again, please return to repair center.
37	LLC hardware fault	Restart the unit, if the error happens again, please return to repair center.
38	BAT hardware fault	Restart the unit, if the error happens again, please return to repair center.
40	PV voltage is too high	Reduce the number of PV modules in series.
41	Short circuited happen at PV port	Check if wiring is connected well.
42	PV power anomaly	Restart the unit, if the error happens again, please return to repair center.
43	Over current happen at PV port	Restart the unit, if the error happens again, please return to repair center.
50	Fan is locked	Check if wiring is connected well. Replace the fan.

51	Over temperature happen at PV circuit	The temperature of internal PV component is over the limitation. Check whether the air flow of the unit is blocked or whether the ambient temperature is too high.
52	Over temperature happen at INV circuit	The temperature of internal INV component is over the limitation. Check whether the air flow of the unit is blocked or whether the ambient temperature is too high.
53	Over temperature happen at Convert L circuit	The temperature of Convert L battery converter component is over the limitation. Check whether the air flow of the unit is blocked or whether the ambient temperature is too high.
54	Over temperature happen at Convert H circuit	The temperature of internal Convert H component is over the limitation. Check whether the air flow of the unit is blocked or whether the ambient temperature is too high.
60	CAN data loss	1. Check if communication cables are connected well and restart the inverter. 2. If the problem remains, please contact your installer.
61	Host data loss	
62	Synchronization data loss	
63	The firmware version of each inverter is not the same	1. Update all inverter firmware to the same version. 2. Check the version of each inverter via LCD setting and make sure the CPU versions are same. If not, please contact your installer to provide the firmware to update. 3. After updating, if the problem still remains, please contact your installer.
64	The output current of each inverter is different	1. Check if sharing cables are connected well and restart the inverter. 2. If the problem remains, please contact your installer.
65	AC output mode setting is different	1. Switch off the inverter and check LCD setting program 20. 2. For parallel system in single phase, make sure no 3P1, 3P2 or 3P3 is set on program 20. For supporting three-phase system, make sure no "PAL" is set on program 20. 3. If the problem remains, please contact your installer.
66	Single unit is installed to parallel system	1. Please check if single unit is installed to parallel system. 2. If this error happens during parallel installation, please check wires connection. If they are connected correctly, please finish parallel installation first, and then restart inverters. 3. If the problem remains, please contact your installer.
99	Update fault	Restart the unit, if the error happens again, please return to repair center.